

SHOP EQUIPMENT

GUARANTEED TO PERFORM



Trusted by Professionals Since 1977

www.sunextools.com



SUNEX TOOLS® WARRANTY PROGRAM

SUNEX INTERNATIONAL, INC. WARRANTS TO ITS CUSTOMERS THAT THE COMPANY'S SUNEX TOOLS® BRANDED PRODUCTS ARE FREE FROM DEFECTS IN WORKMANSHIP AND MATERIALS. Sunex International, Inc. will repair or replace its Sunex Tools® branded products which fail to give satisfactory service due to defective workmanship or materials, based upon the terms and conditions of the following described warranty plans attributed to that specific product.

Sunex Tools Warranty Plans:

Sunex Tools®

These products carry a LIFETIME warranty—effective for as long as you own the product. Sunex International, Inc. will repair or replace at our option any part or unit which proves to be defective in material or workmanship. Adapters and extra thin wall impact sockets are not covered by this warranty.

Sunex Tools® Bench Grinders, Drill Presses, Band Saws and Presses:

These products carry a ONE YEAR warranty. During this warranty period, Sunex International, Inc. will repair or replace at our option any part or unit which proves to be defective in material or workmanship. The SXC series air tools are excluded from this warranty. SXC series tools carry a 1 year replacement warranty.

Sunex Tools® Creepers and Service Carts & Accessories: These products carry an “As Is” warranty. These products are warranted, at the time of sale only, against defects in materials or workmanship that prevent their use.

Sunex Tools® Consumables: A consumable product is warranted, at the time of sale only, against defects in materials or workmanship that prevent its use. Consumable products are goods reasonably expected to be used up or damaged during use, including but not limited to cutting wheels, blades and sanding pads.

SPECIAL NOTE FOR APPLYING WARRANTY PLANS TO PRODUCTS PURCHASED IN SETS:

If a product is purchased as a set, the warranty applies to the individual products within the set but not to the set as a whole. For example, if one item (e.g. an impact socket) in the set is found defective due to manufacturing workmanship, Sunex International, Inc. will replace that individual item (one socket) in the set, but not the entire



Other important warranty information...

This warranty does not cover damage to equipment or tools arising from alteration, abuse, misuse, or damage, and does not cover any repairs or replacement made by anyone other than Sunex Tools® or its authorized warranty service centers. The foregoing obligation is Sunex Tools® sole liability under this or any implied warranty and under no circumstances shall we be liable for any incidental or consequential damages.

Note: Some states do not allow the exclusion or limitation of incidental or consequential damages, so the above limitation or exclusion may not apply to you. Return equipment or parts to Sunex Tools®, or an authorized warranty service center, transportation prepaid. Be certain to include your name and address, evidence of the purchase date, and description of the suspected defect. If you have any questions about warranty service, please write to Sunex Tools®. This warranty gives you specific legal rights and you may also have other rights which vary from state to state. Repair kits and replacement parts are available for many Sunex Tools® products regardless of whether or not the product is still covered by a warranty plan.

Shipping Address: Sunex Tools • 315 Hawkins Rd. • Travelers Rest, SC 29690

Mailing Address: Sunex Tools • P.O. Box 1233 • Travelers Rest, SC 29690

 SERVICE CARTS & ACCESSORIES	2
 CREEPERS	10
 SHOP SEATS	11
 SHOP EQUIPMENT	12
 STAND AND GRINDERS	9
 PRESSES	14
 PRODUCT INDEX	23

SERVICE CARTS & ACCESSORIES



TWO-SHELF SERVICE CART WITH ANODIZED LEGS

- > 4" Easy rolling heavy duty polyurethane swivel casters
- > Ergonomic grip handle
- > 2 Durable polyethylene shelves
- > Anodized aluminum legs

8032

Load Capacity (lbs.)	350
Height (in.)	35
Length (in.)	36.25
Width (in.)	18.5
Shelf Length (in.)	29.5
Shelf Width (in.)	16.75
Shelf Depth (in.)	2
Weight (lbs.)	35



THREE-SHELF SERVICE CART WITH ANODIZED LEGS

- > 4" Easy rolling heavy duty polyurethane swivel casters
- > Ergonomic grip handle
- > 3 Durable polyethylene shelves
- > Anodized aluminum legs

8033

Load Capacity (lbs.)	500
Height (in.)	39.25
Length (in.)	36.25
Width (in.)	18.5
Shelf Length (in.)	29.5
Shelf Width (in.)	16.75
Shelf Depth (in.)	2
Weight (lbs.)	42



SERVICE CART ECONOMY

- > Large, easy to maneuver 4" wheels: 2 locking and 2 standard
- > Durable powder coated finish

Available: Locking Drawer - 8006RB
Locking screw driver/pry bar holder - 8008

8003SC

Load Capacity (lbs.)	350
Height (in.)	32.5
Length (in.)	30
Width (in.)	16
Shelf Depth (in.)	3
Weight (lbs.)	33.10



SERVICE CART WITH LOCKING TOP & DRAWER

- > The locking drawer and locking top use common key
- > Clip-on roller-bearing slides on drawer
- > Large, easy to maneuver 4" wheels - 2 locking and 2 standard
- > Chrome 16 gauge steel frame
- > Durable powder coated finish
- * No weight can be put on cart top*

COLORS ALSO AVAILABLE:



Blue
8013ABL



Black
8013ABK

8013A

Load Capacity (lbs.)	350
Height (in.)	35.3
Length (in.)	30
Width (in.)	16
Top Bin Depth (in.)	3
Drawer Depth (in.)	4
Shelf Depth (in.)	3
Weight (lbs.)	64.45



SERVICE CART MULTI-PURPOSE

- > Large, easy to maneuver 4" wheels-2 locking and 2 standard
- > Chrome 16 gauge steel frame
- > Durable powder coated red finish

Replacement locking caster - **RSSCPLW**
 Replacement non-locking caster - **RSSCPW**
 Replacement plastic caster holders, set of 4 - **RSSCPP1**

8005SC

Load Capacity (lbs.)	350
Height (in.)	35.3
Length (in.)	30
Width (in.)	16
Shelf Depth (in.)	3
Weight (lbs.)	39.33



HEAVY DUTY ADJUSTABLE WORK TABLE WITH DRAWER

- > New feature designed to house air tools
- > Standard screwdriver and pry bar holder
- > 1" deep drawer for convenient storage

Replacement caster with nut - **RS8018CS**



New inset groove design allows air tools to stand upright.
Air tool not included

8019

Load Capacity (lbs.)	220
Low Height (in.)	34
High Height (in.)	47.75
Tray Dimensions (in.)	29 x 20 x 1
Caster Size (in.)	2
Shipping Weight (lbs.)	35.2



**SERVICE CART
4 DRAWER, LOCKING TOP**

> Cart includes: 3 drawer service cart with leg extensions, large locking screwdriver/pry bar holder, and side work bench.

**Drawer liner sold separately*

COLORS ALSO AVAILABLE:



Blue
8013ABDLX



Black
8013ABKDLX

8013ADELUXE

Load Capacity (lbs.)	350
Height (in.)	32.5
Length (in.)	30
Width (in.)	16

Drawer Depths

Top Bin (in.)	3
Twin Top Drawers (in.)	2
Middle Drawer (in.)	2
Bottom Drawer (in.)	4
Bottom Shelf (in.)	3
Weight (lbs.)	131



**PROFESSIONAL
SERVICE CART, 5 DRAWER
WITH ACCESSORIES**

- > 5" Oversized casters: 2 locking, 2 non-locking
- > 75% assembled, making it one of the easiest and quickest carts in the market to put together
- > With a flip top locking lid, 5 drawers all pre assembled with common keyed locks, screwdriver/prybar holder, and side work shelf
- > EVA foam drawer liners included
- > Chrome 16 gauge steel frame and powder coated finish

**Optional: 5pc lock set - 8045LS
Locking screw driver/pry bar holder - 8008**

COLORS ALSO AVAILABLE:



Blue
8045BL



Black
8045BK

8045

Load Capacity (lbs.)	500
Height (in.)	40
Length (in.)	27
Width (in.)	18.25

Drawer Depths

Top Bin (in.)	3
Twin Small Drawers (in.)	2
Top Large Drawer (in.)	2
Middle Large Drawer (in.)	4
Bottom Large Drawer (in.)	6
Bottom Shelf (in.)	3
Weight (lbs.)	116.8

SERVICE CARTS & ACCESSORIES



SERVICE CART 2 DRAWER, LOCKING TOP

- > 5" Oversized casters: 2 locking, 2 non-locking
- > Ergonomic grip handle
- > Locking top
- > Gas shocks to support lid

COLORS ALSO AVAILABLE:



Black
8050BK

8050	
Load Capacity (lbs.)	500
Height (in.)	39.5
Length (in.)	33.25
Width (in.)	20
Drawer Depths	
First Drawer (in.)	3.25
Second Drawer (in.)	4.25
Shipping Weight (lbs.)	176



SERVICE CART 4 DRAWER, LOCKING TOP

- > 5" Oversized casters: 2 locking, 2 non-locking
- > Ergonomic grip handle
- > Locking top
- > Gas shocks to support lid

COLORS ALSO AVAILABLE:



Red
8054

8054BK	
Load Capacity (lbs.)	500
Height (in.)	39.50
Length (in.)	33.25
Depth (in.)	20
Drawer Depths	
Top Bin (in.)	5
Twin Small Drawers (in.)	3.25
Middle Large Drawer (in.)	4.25
Bottom Large Drawer (in.)	5
Bottom Shelf (in.)	3

HYBRID UTILITY CART 4 DRAWER, SLIDING TOP

- > 5" Oversized casters: 2 locking, 2 non-locking
- > Four drawers with clip on roller bearing slides and drawer liners
- > Sliding top work station with large tool storage compartment area underneath
- > Sliding top compartment includes screwdriver holder and protective rubber mats
- > Cart comes assembled, just attach the handle

COLORS ALSO AVAILABLE:



Black
8043

8043R	
Load Capacity (lbs.)	500
Height (in.)	40
Length (in.)	27
Width (in.)	18.25
Drawer Depths	
First Drawer (in.)	1.75
Second Drawer (in.)	4
Third and Fourth Drawers (in.)	6.25
Weight (lbs.)	185.90





**LOCKING
SCREWDRIVER/PRYBAR
HOLDER FOR SERVICE CART**

- > Attaches to 8003SC, 8005SC & 8013A and most other carts (drill holes to attach)
- > Locking lid for security, 2 keys included
- > Durable red powder coated finish

8008	
Capacity	14 items
Height (in.)	3.5
Length (in.)	10.88
Width (in.)	9.13



**LARGE LOCKING SCREWDRIVER/
PRYBAR HOLDER
FOR SERVICE CART**

- > Attaches to 8003SC, 8005SC & 8013A and most other carts (drill holes to attach)
- > 3 different hole sizes: 1", 3/4", and 1/2" diameters
- > Locking lid for security
- > Durable powder coated finish

8011	
Capacity	26 items
Height (in.)	4
Length (in.)	10.88
Width (in.)	16.13

COLORS ALSO AVAILABLE:



Blue
8011BL



Black
8011BK



**SIDE WORK BENCH
FOR 8013A**

- > 30 lb. capacity
- > Folds down when not in use for storage

COLORS ALSO AVAILABLE:



Blue
8004BL



Black
8004BK

8004	
Capacity (lbs.)	30
Height (in.)	5.90
Length (in.)	14.60
Width (in.)	16.34



STORAGE DRAWER FOR SERVICE CART

- > Clip-on roller-bearing slides
- > Attaches to 8005SC & 8013A and most other carts with an inner leg length of at least 28"
- > Up to 2 drawers can be installed on the same cart
- > Durable powder coated finish

8006RB	
Height (in.)	3
Length (in.)	30
Width (in.)	16

COLORS ALSO AVAILABLE:



Blue
8006CRBL



Black
8006CRBK



THIRD SHELF FOR SERVICE CART

- > Attaches to 8005SC & 8013A and most other carts
- > Durable powder coated finish

8007	
Height (in.)	3
Length (in.)	30
Width (in.)	16

COLORS ALSO AVAILABLE:



Blue
8007BL1



Black
8007BK



3 DRAWER UNIT FOR SERVICE CART

- > Clip-on roller-bearing slides
- > Attaches to 8005SC & 8013A and most other carts
- > Up to 2 units can be installed on the same cart
- > Durable powder coated finish

8016	
Small Drawer Dimensions	
Height (in.)	3
Length (in.)	15
Width (in.)	12.25
Large Drawer Dimensions	
Height (in.)	3
Length (in.)	15
Width (in.)	26.5

COLORS ALSO AVAILABLE:



Blue
8016BL



Black
8016BK

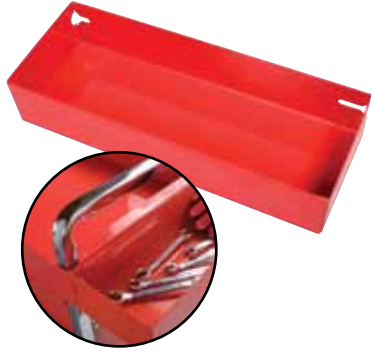

SERVICE CART STORAGE BIN

- > For use with service carts
- > Perfect for storing tools and parts
- > 1.2mm steel

8023

Height (in.)	3.13
Length (in.)	7.13
Width (in.)	16.25

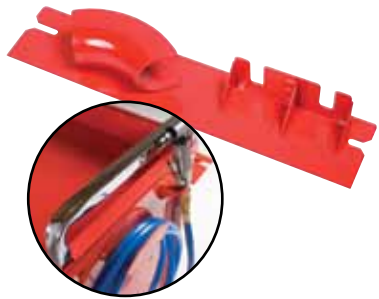

SERVICE CART AIR TOOL AND HOSE RACK ACCESSORY

- > For use with service carts
- > Perfect for keeping air tools and hoses organized and accessible
- > 1.2mm steel

8027

Height (in.)	2.88
Length (in.)	3.25
Width (in.)	16.13



MANUAL RACK FOR SERVICE CART

- > For use with service carts
- > Perfect for organizing and storing important papers, catalogs, magazines and manuals
- > 1.2mm steel

8028

Height (in.)	12
Length (in.)	3.25
Width (in.)	16.13

SERVICE CARTS & ACCESSORIES

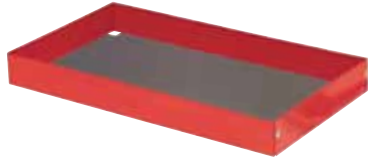

EVA FOAM FOR SERVICE CART TRAY

- > Resistant to most grease and solvents
- > Cut to fit in the service cart tray

1110	
Dimensions (in.)	30 x 16
Quantity included	10



EVA FOAM FOR SERVICE CART DRAWER

- > Resistant to most grease and solvents
- > Cut to fit in the service cart drawer

1111	
Dimensions (in.)	30 x 16
Quantity included	10



RUBBER LINER FOR SERVICE CART SIDE SHELF

- > Ribbed design
- > Resistant to most grease and solvents
- > Cut to fit 8004 series service cart side shelves

8004SSM	
Dimensions (in.)	16.5 x 14.5
Quantity included	10



LEG EXTENSIONS FOR SERVICE CART

- > Add 4.75" to the height of cart
- > Use to maintain shelf clearance when adding additional drawer units
- > Easy to install

8014	
Length (in.)	4.75



4 PIECE LOCK SET FOR SERVICE CART

- > 4 piece lock and key set, all keyed alike

8013LS	
SET INCLUDES:	
Top lock, key & latch	
Drawer lock, key & latch	
3 drawer unit lock, key & latch	
Prybar/screwdriver holder lock, key & latch	



4 CASTER CREEPER

- > Powder coated black frame
- > Cushioned red vinyl cover
- > High quality casters for easy rolling

Replacement caster - 8503
(Includes 1 caster, 2 inserts, & 2 lock washers)

8504

Max Capacity (lbs.)	250
Length (in.)	36
Caster Size (in.)	2.5
Frame Dimensions:	36 x 17 x 3.5
Ground Clearance (in.)	1.75



6 CASTER CREEPER WITH ADJUSTABLE HEAD REST

- > Powder coated black frame
- > Cushioned red vinyl cover with adjustable head rest

Replacement caster - 8503
(Includes 1 caster, 2 inserts, & 2 lock washers)

8505

Max Capacity (lbs.)	250
Length (in.)	40
Caster Size (in.)	2.5
Frame Dimensions (in.)	40 x 17 x 4
Ground Clearance (in.)	1.75



PLASTIC CREEPER

- > 40" ergonomically designed frame
- > 4-3/4" high vinyl covered foam headrest for maximum comfort
- > Two storage trays conveniently located on either side
- > A low profile of 1" allows for greater clearance under vehicles
- > Made of material that is resistant to most solvents, grease and oils found in the common shop

Replacement caster - RS8511CS

8511

Max Capacity (lbs.)	250
Caster Size (in.)	3
Length (in.)	40
Ground Clearance (in.)	1



COMFORT EXTREME CREEPER

- > 1" Rugged steel tube construction
- > Oversize frame for added comfort
- > Tapered frame and head rest for extra clearance in tight areas
- > Heavy duty chrome finished casters with rubber tread
- > 5- Position stick shift headrest adjustment system
- > Rear drop frame design for extra leg comfort

Replacement caster - RS8515CS

8515

Capacity (lbs.)	300
Caster Size (in.)	3.5
Length (in.)	45.5
Width (in.)	19
Height (Headrest Down) (in.)	5
Height (Headrest Up) (in.)	9.5
Bed Size	30.63 x 16.5 x 2.5
Head Rest Size (in.)	30.5
Tapered to	10
Height Of Head Rest (in.)	
Position 1	5
Position 2	6
Position 3	7.5
Position 4	8.5
Position 5	9.5
Ground Clearance (in.)	1.75

PADDED CREEPER SEAT

- > Cushioned vinyl seat with 2" high compression foam
- > Powder coated black frame for long lasting finish
- > Includes convenient 1" deep parts tray
- > 1 caster, 2 inserts, & 2 lock washers

Replacement caster - 8503
(Includes 1 caster, 2 inserts, & 2 lock washers)

8507

Max. Capacity (lbs.)	300
Caster Size (in.)	2.5
Seat Dimensions (in.)	8 x 14
Tray Dimensions (in.)	11.5 x 12.5
Frame Dimensions	
Height (in.)	14
Length (in.)	17

EZ SET™ PNEUMATIC PROFESSIONAL SHOP SEAT

- > Air cylinder for easy height adjustment
- > Cushioned black vinyl covered wooden seat
- > Large steel reinforced tool tray

Replacement caster - RS8509WH
(Includes 1 caster, 1 nut & 1 lock washer)

8509

Max Capacity (lbs.)	300
Caster Size (in.)	2.5
Seat Diameter (in.)	12.5
High Height (in.)	20.5
Low Height (in.)	15.5
Tool Tray	
Diameter (in.)	15.25
Depth (in.)	1

SWIVEL TRACTOR SEAT

- > Air cylinder for easy height adjustment
- > Heavy duty, chrome finished casters with rubber tread for ease of mobility
- > Large steel reinforced tool tray

Replacement caster - RS8515CS

8514

Max Capacity (lbs.)	300
Caster Size (in.)	3.5
Low Height (in.)	18
High Height (in.)	22
Seat Width (in.)	16
Tool Tray	
Diameter (in.)	17
Depth (in.)	1

18" OVERSIZED SWIVEL TRACTOR SEAT

- > 18" wide, cushioned seat for maximum comfort
- > Well balanced round base
- > Large steel reinforced tool tray

Replacement caster - RS8509WH
(Includes 1 caster, 1 nut & 1 lock washer)

8518

Max Capacity (lbs.)	300
Caster Size (in.)	2.5
Low Height (in.)	16
High Height (in.)	21
Seat Width (in.)	18
Seat Depth (in.)	14
Tool Tray	
Diameter (in.)	17
Depth (in.)	1



16 SPEED DRILL PRESS

- > Heavy duty 3/4 HP motor with 5/8" drill capacity
- > Convenient belt tension lever for quick speed transition
- > Table rotates 360° and pivots from 0° to 45° on each side with indicator to facilitate setting
- > UL & CSA Listed

Replacement 5/8" chuck & key - RS5000A87
Fits standard MT2 Arbor

5000A	
Power	3/4 HP
Power Source	115V/60Hz
Speeds Range	200 - 3850 RPM
Max Spindle Stroke (in.)	3.13
Spindle Nose	#2
Diameter of Column (in.)	2.75
Table Diameter (in.)	11.5
Height (in.)	61.8



6" VISE

- > 2 locking mechanisms for stability
- > Made from cast iron with steel handle threads

Replacement jaws (1 pair) - RS500405

5004	
Base Swivel	360°
Max Vise Opening (in.)	6

UNDER HOIST TRANSMISSION JACKS



6" BENCH GRINDER WITH LIGHT

- > Bright, flexible work light
- > Has two 6" grit wheels: coarse 36 and medium 60
- > Each wheel has protective spark guard and adjustable eye shield
- > Mounting holes and rubber feet make grinder easy to mount on a stand (optional - part #5003 or 5005A) or use on an approved worktable or workbench
- > Conveniently placed, easy to use on/off switch
- > Long, 6-foot power cord
- > Cast iron base for durability
- > Ball bearing construction for smooth operation
- > 1/2" Arbor accepts standard 6" wheel
- > Uses regular incandescent light bulbs (check head for max wattage)
- > UL & CSA Listed and meets OSHA requirements

Replacement eye shields - RS500119B

Replacement tool rests - RS500135B

5001A

Power	1/2 HP Motor
No Load Speed	3450 RPM
Motor	3.5 Amp
Voltage	115V/60Hz



8" BENCH GRINDER WITH LIGHT

- > Bright, flexible work light
- > Has two 8" grit wheels: coarse 36 and medium 60
- > Each wheel has protective spark guard and adjustable eye shield
- > Mounting holes and rubber feet make grinder easy to mount on a stand (optional - part #5003 or 5005A) or use on an approved worktable or workbench
- > Conveniently placed, easy to use on/off switch
- > Long, 6-foot power cord
- > Cast iron base for durability
- > Ball bearing construction for smooth operation
- > 5/8" Arbor accepts standard 8" wheel
- > UL & CSA Listed and meets OSHA requirements

Replacement eye shields - RS500219B

Replacement tool rests - RS500135B

5002A

Power	3/4 HP Motor
No Load Speed	3450 RPM
Motor	5 Amp
Voltage	115V/60Hz



BENCH GRINDER STAND

- > Sturdy base with pre-drilled holes for mounting on floors
- > Use with 5001A & 5002A and other 6" or 8" bench grinders

5003

Base Mounting Area (in.)	10.5 x 7.5
Height (in.)	36
Pipe Shaft Dimensions	
Diameter (in.)	3
Height (in.)	26.63

**SUNEX SHOP PRESSES AND ACCESSORIES
BUILT IN THE USA**

Sunex® has over 30 years experience in the design and manufacturing of shop presses and accessories for the automotive, heavy duty truck and industrial markets. Sunex® is the professional technician's most valuable source for heavy duty shop equipment with presses available in all capacities from 12 to 150 ton and your choice of manual, air/hydraulic or electro-hydraulic power supplies. Additional shop press models and information can be obtained by logging on to www.amerequiplifting.com

All welded steel construction,
crafted in the USA



Heavy duty ram
(electric or quick-
return spring)

Winch bed lift with automatic
braking (available on 40, 50,
100 & 150 ton models)



Bed plates and bearing
punch come standard

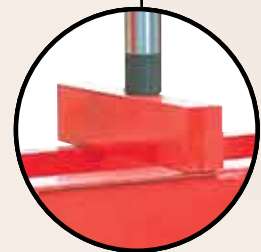

ECONOMY SHOP PRESSES

MODEL 5212 12 TON CAPACITY SHOP PRESS

Used for various shop applications including straightening, bending, and removing/installing gears, bearings and bushings.

FEATURES:

- > US built welded press frame to prevent excessive flexing under maximum load.
- > Reinforced head bolster for added strength.
- > Heavy duty return springs for fast ram retraction.
- > Pair of bed plates and ram head included.



MODEL 5212 12 TON



MODEL 5220 20 TON

MODEL 5220 20 TON CAPACITY SHOP PRESS

Same use and features as the model 5212 with added capacity.

AIR/ HYDRAULIC SHOP PRESS MODELS 5212AH 12 TON CAPACITY 5220AH 20 TON CAPACITY

Same use and features as the models 5212 and 5220 with the added operating convenience of depressing an air valve. Equipped with a manual pump for use when an air supply is not available.



MODEL 5212AH 12 TON
5220AH 20 TON (SHOWN)

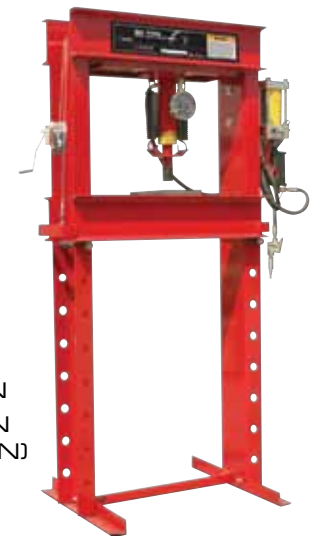

MODEL 5220PR 20 TON

MODEL 5220PR 20 TON CAPACITY AIR/ HYDRAULIC SHOP PRESS

Same use and features as the model 5220AH with all welded US frame construction and US built power supply.

NOTE: Optional accessories and kit: see pages 20-22 for full details.

MODEL #	Capacity (tons)	Overall Height (in.)	Base Width (in.)	Vertical Throat Opening (in.)	Throat Width (in.)	Ram Stroke (in.)	Ram Dia. (in.)	Cylinder Bore (in.)	Weight (lbs.)
5212	12	61.5	26	3.75 to 36	20	6.1	-	-	200
5220	20	64.5	26	1.5 to 33	24.5	6	-	-	265
5212AH	12 @ 100 PSI	61.5	26	3.75 to 36	20	6.1	-	-	205
5220AH	20 @ 100 PSI	64.5	26	1.5 to 33	24.5	6	-	-	270
5220PR	20 @ 100 PSI	66.5	26	1.5 to 33	28	4.75	1.5	2.5	300

U.S. MADE SHOP PRESSES

MODEL 5240 40 TON CAPACITY ELECTRO-HYDRAULIC SHOP PRESS

Used for various shop applications including straightening, bending, and removing/installing gears, bearings and bushings.

FEATURES:

- > US built welded press frame to prevent excessive flexing under maximum load.
- > Reinforced head bolster for added strength.
- > 2HP Emerson electric motor, 110 volt
- > 4" Diameter gauge reads internal working pressure and force in tons.
- > Heavy duty internal return springs for fast ram retraction.
- > Pair of bed plates and ram head included.

MODEL 5240AO 40 TON CAPACITY AIR/HYDRAULIC SHOP PRESS

Same use as the model 5240 but powered by an air/hydraulic pump.

FEATURES:

- > US built welded press frame to prevent excessive flexing under maximum load.
- > Reinforced head bolster for added strength.
- > Air/hydraulic pump for quicker cycling times by depressing air valve at the end of a four foot air line.
- > 4" Diameter gauge reads US tons and corresponding metric tons.
- > Heavy duty springs for fast ram retraction.
- > Pair of bed plates and ram head included.

MODEL 5240MP 40 TON CAPACITY SHOP PRESS

Same use as the model 5240 but powered by a manual operated pump.

FEATURES:

- > US built welded press frame to prevent excessive flexing under maximum load.
- > Reinforced head bolster for added strength.
- > Dual piston pump provides quicker extension of ram to the work load and easier pumping under load.
- > Pump includes overload valve to prevent against overloading.
- > Winch with non-slip safety clutch and steel cable rollers for easy raising and lowering of press bed.
- > 4" Diameter gauge reads US tons and corresponding metric tons.
- > Heavy duty springs for fast ram retraction.
- > Pair of bed plates and ram head included.

NOTE: Optional accessories and kit: see pages 20-22 for full details.



MODEL 5240 40 TON



MODEL 5240AO 40 TON



MODEL 5240MP 40 TON

MODEL #	Capacity (tons)	Overall Height (in.)	Base Width (in.)	Vertical Throat Opening (in.)	Throat Width (in.)	Ram Stroke (in.)	Ram Dia. (in.)	Cylinder Bore (in.)	Weight (lbs.)
5240	40	76.25	32	1 to 40	32	8.25	2	6	540
5240AO	40 @ 100 PSI	76.25	32	1 to 40	32	6.75	2	3.5	478
5240MP	40	76.25	32	1 to 40	32	4.5	2	3.5	470

**MODEL 5250EP
50 TON CAPACITY
ELECTRO-HYDRAULIC SHOP PRESS**

Used for various shop applications including straightening, bending, and removing/ installing gears, bearings and bushings.

FEATURES:

- > US built welded press frame to prevent excessive flexing under maximum load.
- > Reinforced head bolster for added strength.
- > 2HP Emerson electric motor, 110 volt.
- > Two speed pump with remote pendant control.
- > 4" Diameter gauge reads internal working pressure and force in tons.
- > Winch with non-slip safety clutch and steel cable rollers for easy raising and lowering of press bed.
- > Heavy duty internal return springs for fast ram retraction.
- > Pair of bed plates and ram head included.



MODEL 5250EP 50 TON

**MODEL 5250
50 TON CAPACITY
SHOP PRESS**

Same use as the model 5250EP but powered by a manual operated pump.

FEATURES:

- > US built welded press frame to prevent excessive flexing under maximum load.
- > Reinforced head bolster for added strength.
- > Dual pump pistons provide quicker ram extension to the work load and easier pumping under load.
- > Pump includes overload valve to prevent against overloading.
- > 4" Diameter gauge reads US tons and corresponding metric tons.
- > Winch with non-slip safety clutch and steel cable rollers for easy raising and lowering of press bed.
- > Heavy duty external return springs for fast ram retraction.
- > Pair of bed plates and ram head included.



MODEL 5250 50 TON

NOTE: Optional accessories and kit: see pages 20-22 for full details.

MODEL #	Capacity (tons)	Overall Height (in.)	Base Width (in.)	Vertical Throat Opening (in.)	Throat Width (in.)	Ram Stroke (in.)	Ram Dia. (in.)	Cylinder Bore (in.)	Weight (lbs.)
5250EP	50	74	35	1.5 to 34	35	8.25	2	6	582
5250	50	74	35	1.5 to 34	35	6.75	2	3.5	513

U.S. MADE SHOP PRESSES

MODEL 52100 100 TON CAPACITY AIR/HYDRAULIC SHOP PRESS

Used for various shop applications including straightening, bending, and removing/installing gears, bearings and bushings.



FEATURES:

- > US built welded press frame to prevent excessive flexing under maximum load.
- > Reinforced head bolster for added strength.
- > 1/3HP Haskel air motor for dependable service.
- > 4" Diameter gauge reads US tons and corresponding metric tons.
- > Winch with non-slip safety clutch and steel cable rollers for easy raising and lowering of press bed.
- > Heavy duty internal return springs for fast ram retraction.
- > Pair of bed plates and ram head included.

MODEL 52100 100 TON

NOTE: Optional accessories and kit: see pages 20-22 for full details.

MODEL #	Capacity (tons)	Overall Height (in.)	Base Width (in.)	Vertical Throat Opening (in.)	Throat Width (in.)	Ram Stroke (in.)	Ram Dia. (in.)	Cylinder Bore (in.)	Weight (lbs.)
52100	100 @ 100 PSI	78	36	1 to 32	34	7	2.5	5.5	1106

**MODEL 52150
150 TON CAPACITY
AIR/HYDRAULIC SHOP PRESS**

Used for various shop applications including straightening, bending, and removing/installing gears, bearings and bushings.



FEATURES:

- > US built welded press frame to prevent excessive flexing under maximum load.
- > Reinforced head bolster for added strength.
- > 1/3HP Haskel air motor for dependable service.
- > 4" Diameter gauge reads US tons and corresponding metric tons.
- > Winch with non-slip safety clutch and steel cable rollers for easy raising and lowering of press bed.
- > Heavy duty internal return springs for fast ram retraction.
- > Pair of bed plates and ram head included.

MODEL 52150 150 TON

NOTE: Optional accessories and kit: see pages 20-22 for full details.

MODEL #	Capacity (tons)	Overall Height (in.)	Base Width (in.)	Vertical Throat Opening (in.)	Throat Width (in.)	Ram Stroke (in.)	Ram Dia. (in.)	Cylinder Bore (in.)	Weight (lbs.)
52150	150 @ 100 PSI	78	36	1 to 28	36	7	3	6.5	1550

PRESS KITS

MODEL 52PAK8 PRESS ACCESSORY KIT

FEATURES

- > For use with presses up to 50 tons
- > Five punch sizes, 1/2", 3/4", 1", 1-1/2" and 2"
- > Two 14" x 3" x 1" steel press plates
- > One bearing shield

MODEL 52PPK5 5 PIECE PRESS PUNCH KIT

FEATURES

- > For use with presses up to 50 tons
- > Five punch sizes, 1/2", 3/4", 1", 1-1/2" and 2"

MODEL 52PPK3 3 PIECE PUNCH KIT

FEATURES

- > For use with presses up to 50 tons
- > 1/2", 1" and 2" punches

MODEL 52PAK6 6 PIECE PRESS ACCESSORY KIT

FEATURES

- > For use with presses up to 50 tons
- > 1/2", 1" and 2" punches
- > Two 14" x 3" x 1" steel press plates
- > One bearing shield

MODEL 52PP2 2 PIECE 20 TON PRESS PLATES

FEATURES

- > For use with 12 and 20 ton hydraulic presses
- > Two, 12" x 3" x 3/4" steel press plates
- > Stable base for bearing or punch work

MODEL 52PP4 3 PIECE PUNCH KIT

FEATURES

- > For use with 12 and 20 ton hydraulic presses
- Four, 12" x 3" x 3/4" steel press plates
- Stable base for bearing or punch work

MODEL 52BWK40 BOLT ON WINCH KIT 40 TON PRESS

FEATURES

- > For use with presses up to 50 tons
- > 1/2", 1" and 2" punches
- > Five punch sizes, 1/2", 3/4", 1", 1-1/2" and 2"

MODEL
52PAK8

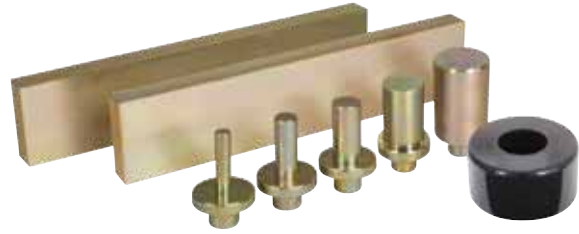

MODEL
52PPK5



MODEL
52PPK3



MODEL
52PAK6



MODEL
52PP2



MODEL
52PP4



MODEL
52BWK40



Note: all model numbers in kit are available individually. See Page 21.

PUNCHES, BED PLATES AND V-BLOCKS

PUNCHES

FEATURES

> All punches are made of precision machined, cold finished 1018 steel and are yellow zinc plated for durability.

12, 20, 40 AND 50 TON CAPACITY

INCLUDES:

MODELS:

- 212028** 1/2" Dia. Punch (0.58 lbs.)
- 212029** 3/4" Dia. Punch (0.66 lbs.)
- 212031** 1" Dia. Punch (0.74 lbs.)
- 212032** 1-1/2" Dia. Punch (1.08 lbs.)
- 212033** 2" Dia. Punch (1.62 lbs.)

100 AND 150 TON CAPACITY

INCLUDES:

MODELS:

- 212105** 3" Dia. Punch (1.6 lbs.)
- 212106** 3" Dia. Punch with V-Groove (1.38 lbs.)

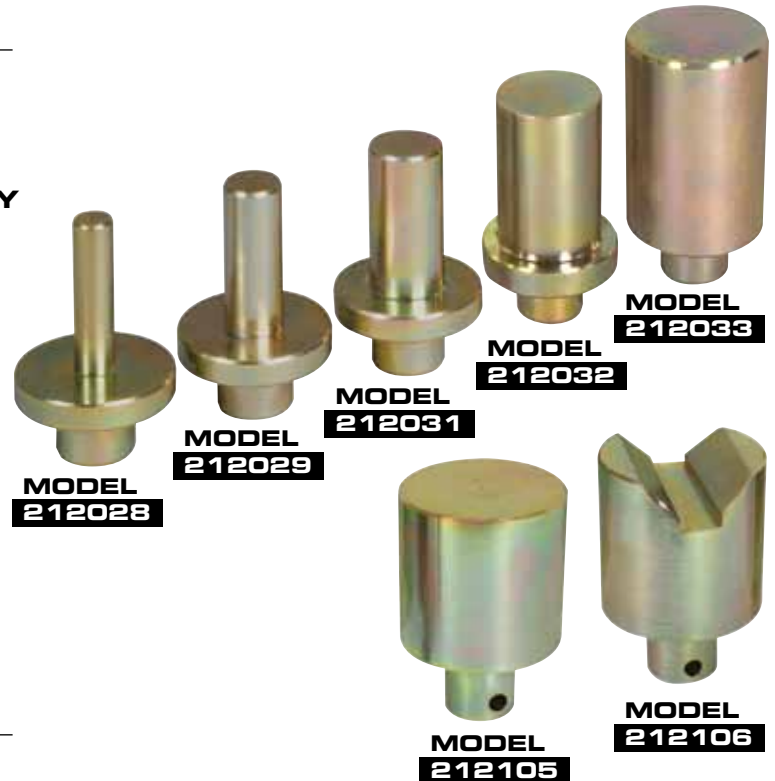

BED PLATES

INCLUDES:

MODELS:

- 212038** 12 and 20 Ton Bed Plates (pair) 1"x 3"x 14" (23.5 lbs.)
- 212039** 40 and 50 Ton Bed Plates (pair) 1"x 3"x 16" (27.5 lbs.)
- 212041** 100 and 150 Ton Bed Plates (pair) 2"x 4"x 20" (92 lbs.)



V-BLOCKS

FEATURES

> All v-blocks are made of precision machined, cold finished 1018 steel and are yellow zinc plated for durability, sold in pairs, excluding model 212037.

12 AND 20 TON CAPACITY

INCLUDES:

MODELS:

- 212027** 12 and 20 Ton V-Blocks (pair) 3"x 3"x 14"; the v-groove is 2.375" wide and .937" deep (75.5 lbs.)

212037

- 12 and 20 Ton Deep V-Block 3/4" x 12"x 14-1/2"; the v groove is 6" wide and 7-1/4" deep (32.1 lbs.)

40 AND 50 TON CAPACITY

212053

- 40 and 50 Ton V-Blocks (pair) 3"x 3"x 16"; the v-groove is 2.625" wide and .937" deep (78.5 lbs.)

100 AND 150 TON CAPACITY

212104

- 100 and 150 Ton V-Blocks (pair) 2"x 4"x 20"; the v-groove is 3.750" wide and 1.937" deep (89.5 lbs.)



- MODEL 212038** 12 & 20 TON
- 212039** 40 & 50 TON
- 212141** 100 & 150 TON

Note: All models have same basic construction.

- MODEL 212027** 12 & 20 TON
- 212053** 40 & 50 TON
- 212104** 100 & 150 TON

Note: All models have same basic construction.

- MODEL 212037** 12 & 20 TON

BEARING SPLITTERS

BEARING SPLITTERS

FEATURES

- > Splitter halves made of forged steel with sharp angled edges to get in between tightly assembled parts.
- > Splitter halves include threaded holes for the acceptance of pushing/pulling attachments.
- > Zinc plating and black oxide coating inhibit rust.

*Bearing Splitters made in Taiwan.



Model #	Spread (in.)		Tapped Hole Size in Splitter Halves (in.)	Distance Between Adjustment Screws (in.)	Shipping Weight
	From	To			
185002	1/4	15/16	5/16"-18	1-11/16	12 oz.
185005	1/8	2	3/8"-16	2-7/16	1 Lb., 4 oz.
185007	1-3/4	5-7/8	5/8"-18	6	4 Lbs., 4 oz.
185025	1/2	4-5/8	5/8"-18	4-3/8	5 Lbs.
185026	1/2	9	5/8"-18	6	12 Lbs., 9 oz.
185050	5/8	8	1"-14	7-1/8	19 Lbs., 12 oz.

MODEL 185055 BEARING SPLITTER SET

FEATURES

- > Rotomolded plastic carrying case with individual recesses for organized bearing splitter storage. Case provides easy access to splitters.
- > Set includes four of the most commonly used bearing splitters and pulley pulling tool. See chart above for specifications on models 185002, 185005, 185025, 185026 bearing splitters and model 185007 pulley pulling tool.

*Bearing Splitters made in Taiwan.



A
 Accessories, Carts 6-9
 Air Tool & Hose Rack, Carts 8
 Accessories & Kits, Presses 20-22

B
 Bench Grinder 13
 Bed Plates, Presses 21
 Bearing Splitters, Presses 22

C
 Creepers 10

D
 Drawers, Carts 7
 Drill Press 12

E
 EVA Foam, Carts 9

G
 Grinder Stand 13
 Grinders 13

L
 Leg Extensions, Carts 9
 Lock Set, ,Carts 9

M
 Manual Rack, Carts 8

P
 Press Blocks, Presses 21
 Punches, Presses 21

R
 Rubber Liner, Carts 9

S
 Service Carts 2-5
 Storage Bins, Carts 8
 Seats 11
 Shop Presses 14-19

V
 Vise 12

W
 Work Table 3

<u>Model #</u>	<u>Page</u>
1110.	.9
1111.	.9
5003.	.13
5004.	.12
5212.	.15
5220.	.15
5240.	.16
5250.	.17
8004.	.6
8007.	.7
8008.	.2,4,6
8011.	.6
8014.	.9
8016.	.7
8019.	.3
8023.	.8
8027.	.8
8028.	.8
8032.	.2
8033.	.2
8043.	.5
8045.	.4
8050.	.5
8054.	.5
8503.	.11
8504.	.10
8505.	.10
8507.	.11
8509.	.11
8511.	.10
8514.	.11
8515.	.10
8518.	.11
52100.	.18
52150.	.19
185002.	.22
185005.	.22
185007.	.22
185025.	.22
185026.	.22
185050.	.22
185055.	.22
212027.	.21

<u>Model #</u>	<u>Page</u>
212028.	.21
212029.	.21
212031.	.21
212032.	.21
212033.	.21
212037.	.21
212038.	.21
212039.	.21
212041.	.21
212053.	.21
212104.	.21
212105.	.21
212106.	.21
5000A.	.12
5001A.	.13
5002A.	.13
5006A.	.12
5212AH	.15
5220AH	.15
5220PR.	.15
5240AO	.16
5240MP	.16
5250EP.	.17
52BWK40	.20
52PAK6.	.20
52PAK8.	.20
52PP2.	.20
52PP4.	.20
52PPK3.	.20
52PPK5.	.20
8003SC	.2
8004BK	.6
8004BL.	.6
8004SSM	.9
8005SC	.3
8006CRBK	.7
8006CRBL.	.7
8006RB.	.2
8006RB.	.7
8007BK	.7
8007BL1.	.7
8011BK	.6
8011BL.	.6

<u>Model #</u>	<u>Page</u>
8013A.	.3
8013ABK.	.3
8013ABKDLX.	.4
8013ABL.	.3
8013ABLDLX.	.4
8013ADELUXE.	.4
8013LS.	.9
8016BK	.7
8016BL.	.7
8043R.	.5
8045BK	.4
8045BL.	.4
8050BK	.5
8054BK	.5

Distributed by:

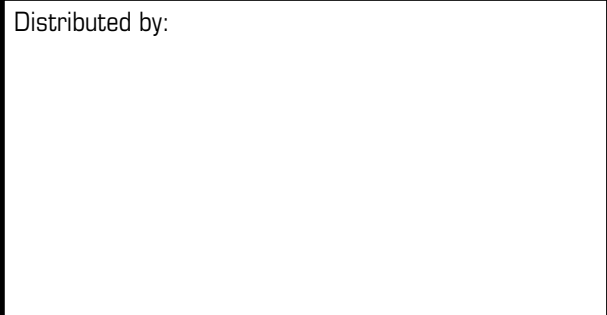

www.sunextools.com

Shipping Address: Sunex Tools • 315 Hawkins Rd. • Travelers Rest, SC 29690

Mailing Address: Sunex Tools • PO Box 1233 • Travelers Rest, SC 29690

Sunex Tools® Service: 877.786.3939 • Toll Free: 1.800.833.7869

Fax: 864.834.7954



REF: SXCS191-12

Rev. 04/10/12